

## Crane scale

Crane scale with capacities from 1000 kg to 5000 kg. The crane scale has a rotation of 360°.



BAT INT



AC/DC



NO VERIF

### FEATURES:

- » LED display with digits of 35mm.
- » Crane scale scale with a rotation of 360°.
- » It can be used in dusty environments.
- » Power supply with adaptor AC/DC 230-240Vac 50Hz.
- » Interior rechargeable battery 6V/4,5 Ah. It lasts 60 hours.
- » External charge with charge signal.
- » Low battery sign.
- » Control of functions, calibration and switch off through remote control.
- » Calibration via remote control.
- » Maximum distance from the remote control: 10m.
- » Units: kg and lb.
- » Standby function and auto switch off.
- » According to the directive of security of the machine 2006/42/CE.

### FUNCTIONS:

- » Accumulation
- » Zero
- » Tare
- » Hold (to set weigh)

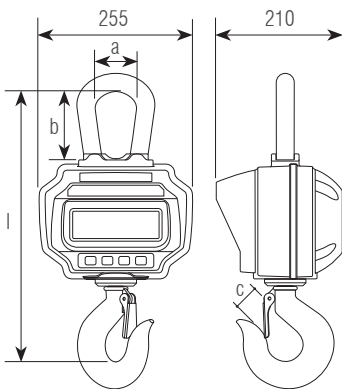

Dimensions (mm)	a	b	c	l	Net weight (kg)
260544	68	112	35	420	11.0
260545	68	112	40	420	11.0
260546	68	112	45	450	12.5

Code #	Capacity (kg)	Readout (g)	n Divisions	Packing dimensions (mm)	Packaging weight (kg)	Certifications	
						ENAC	Code #
260544	1000	500	2000	590x320x280	14,5	ENAC	901015
260545	3000	1000	3000	590x320x280	14,5	ENAC	901016
260546	5000	2000	2500	590x320x280	14,5	ENAC	901017